



# GIR6-2311-0320

MEDICAL  
CART COMPANY

## Accutronics Vyaire Fabian HFO Cart

DIN Rails, Cable hook and Humidifier mount

### Giraffe 6 Range



*Ergonomic*



*Easy to clean*



*Multi purpose*



*Lifetime warranty*



*Quick setup*



## FEATURES



*Designed and manufactured in Hungary, products are typically 100% recyclable and upgradable in the future. Raw materials are sourced locally or in the EU.*

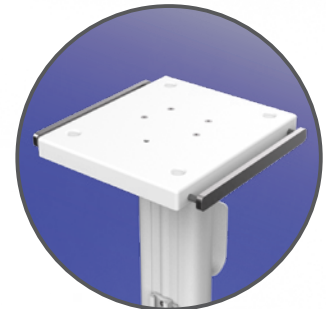

*Safe device mounting*



*Humidifier mount and cable hook*



*Lockable wheels*

# Cart Properties

Dimensions and mechanical data



More info  
on website

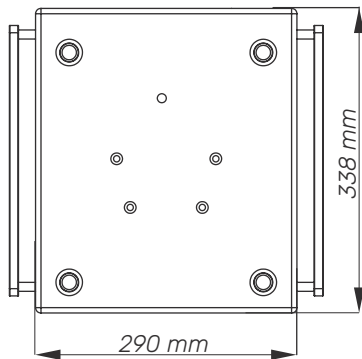

Mounting plate

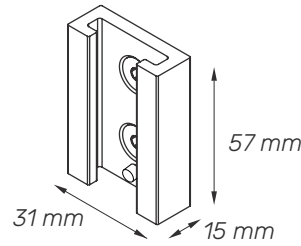

Humidifier mount

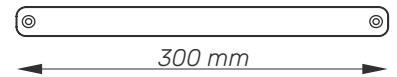

DIN Rail

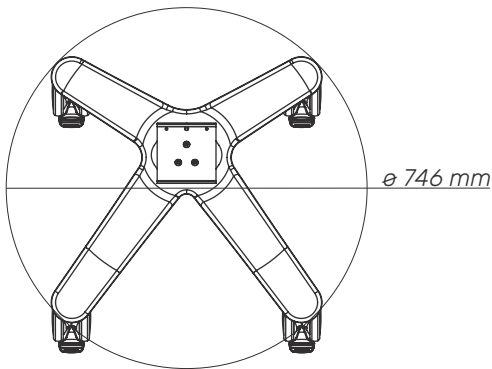

Base

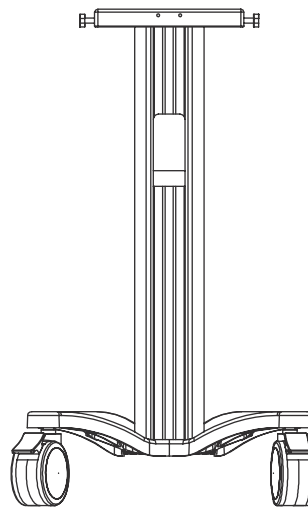

Front

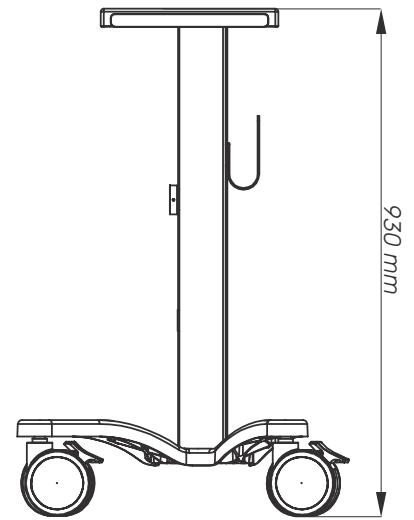

Side



## Mechanical data

Height	930 mm
Wheelbase dimension	746 mm (diameter)
Wheel construction	Polyamide with Polyurethane tread
Wheels/locking	2 lockable, 100 mm diameter
Loading capacity	35 kg

## Construction

Main material	Aluminium
---------------	-----------

## Color

RAL 9016	
Custom color	

## Certificates

Certificates conforms to	IEC60601-1:2012 (Edition 3)
CE	Rohs compliant