

Tablet Mount Budgie Cart for 9.5-16.5 tablets



Ergonomic



Easy to clean



Multi purpose



Lifetime warranty



Quick setup

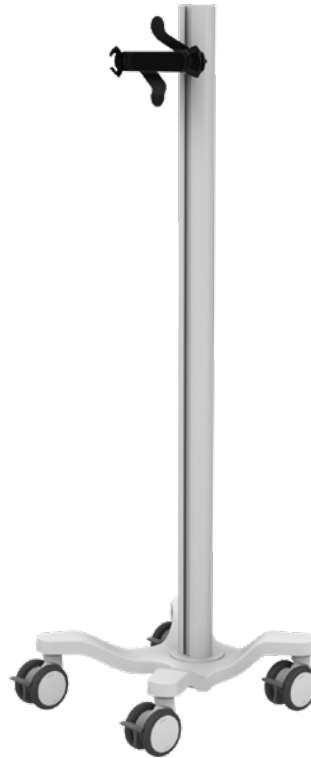

FEATURES



Designed and manufactured in Hungary, products are typically 100% recyclable and upgradable in the future. Raw materials are sourced locally or in the EU.

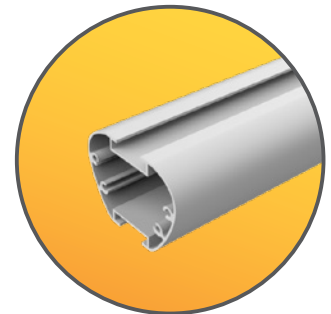

Channels to fix accessories



Tablet mount



Lockable wheels

Cart Properties

Dimensions and mechanical data



More info
on website



Accessories
available



Tablet Mount
Datasheet

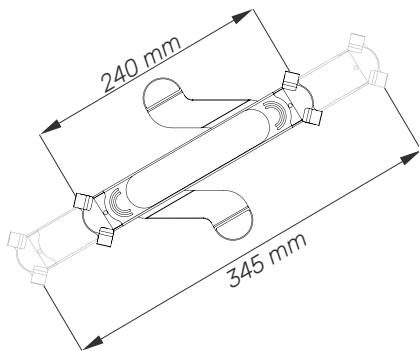

Tablet Mount

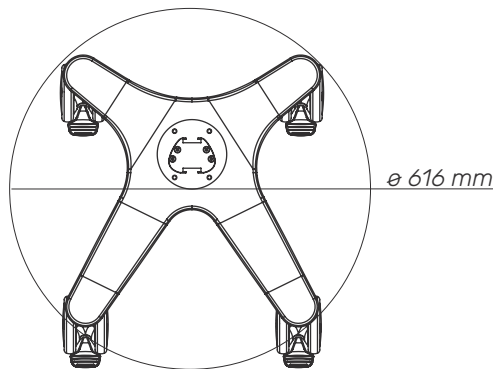

Base

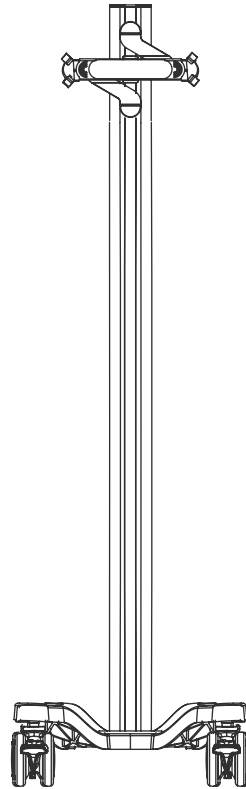

Front

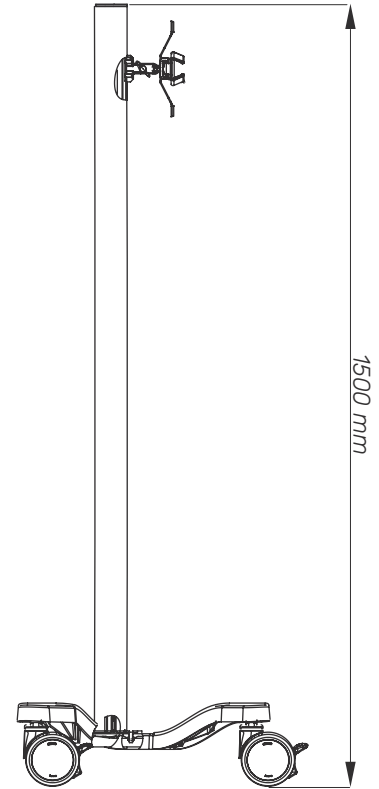

Side

Mechanical data

Height	1500 mm	
Wheelbase dimension	616 mm (diameter)	
Wheel construction	Polyamide with Polyurethane tread	
Wheels/locking	2 lockable, 100 mm diameter	
Loading capacity	36 kg	
Tablet mount diameter	Basic: 9.5"-13.5"	Large: 13.5"-16.5"

Construction

Main material	Aluminium
---------------	-----------

Color

RAL 9016	
Custom color	

Certificates

Certificates conforms to	IEC60601-1:2012 (Edition 3)
CE	Rohs compliant